

DIRAC

Dirac Live Bass Control

Authors

Lars-Johan Brännmark
Frans Rosencratz
Mikael Ueno Andersson

Contents

Dirac Live Bass Control User Guide 4

Equipment Requirements 5

Setup 5

Room Correction Steps 6

User account and audio system 6

Volume calibration 7

Select Arrangement 8

Filter Design 9

Technical Background 13

Dirac Live Bass Control 14

The Bass Management Problem 14

Why Dirac Live Bass Control? 14

Limitations 14

Details of Dirac Live Bass Control 15

Crossover filters 15

Handling of multiple subwoofers 16

Single channels and stereo pairs 17

Generalized Low-frequency Support 17

This document covers Dirac Live Bass Control inside the Dirac Live application and is divided into two parts:

- Section 1:

User Guide

The first section is a user guide that goes through the work process of how to measure the system and adjusting the compensation parameters to create a room compensation filter with Bass Control.

An item in a blue box contains additional information relevant to the discussion.

- Section 2:

Optional: Technical Details

The second section is a technical explanation detailing the workings of bass management and Dirac Bass Control for the users interested in the scientific details and how the system achieves the results. Note that this section is highly technical and is not required to use Bass Control.

An item in a red box is additional or technical information for advanced usage.

Last revision at April 16, 2020

1. Dirac Bass Control User Guide

Frans Rosencrantz
Mikael Ueno Andersson

Whereas Dirac Live 2 introduced the next generation of the *Dirac Live Room Correction* technology, Dirac Live 3 builds on this and introduces the new *Dirac Bass Control* technology for compliant devices.

Dirac Live Bass Control is a technology to manage low-frequency channel routing from the signal to the playback channels (speakers) of your audio device. Additionally, with full control over the device's channel and frequency routing and output, the Dirac Live room correction technology is significantly augmented. In particular systems with multiple subwoofers will see a substantially improved room correction and bass performance.

This section presents the Bass Control user-guide and the required equipment in order to do the calibration.

Key terms:

- **Dirac Live:** The Dirac technology to process audio to correct an audio device's output for the acoustics of the listening environment. Also the name of the application providing this technology.
- **Dirac Live Bass Control:** The Dirac technology to enable all speakers to act in support of each other by routing bass-frequency audio from an input source to output channels. This name covers two aspects, *bass management* and *bass control*:
 - **Bass management:** routing and mixing of source audio optimally between output channels.
 - **Bass control:** calculating inter-speaker support to enable room correction beyond the capability of individual speakers.

Equipment Requirements

The steps below present required equipment and configuration for a Dirac Live Bass Control calibration.

- An omnidirectional calibration microphone with associated calibration file to measure the room.
- The system requires at least one subwoofer and one large/small-range speaker. There is no maximum limit on the number of speakers in the system.
- There are no real requirements of where the subwoofer(s) should be placed in the room. One of the main goals of Bass Control is to let the user position their subwoofer(s) anywhere in the room and still get a good result.
- Each subwoofer should have its own logical channel. Two subwoofers connected to a Y-split is not recommended.
- If the subwoofer(s) has an adjustable low-pass filter, it should be set at the maximum frequency.
- The volume or phase controls should not be touched after a Dirac Live Bass Control calibration since it will affect the results. Any adjustment after calibration should be made in the Dirac Live application.
- There should be no external up-mix in the audio path. If the user wants to add additional filters or effects, it should be applied to the input of the target Dirac Live Bass Control device.

Setup

1. If the unit comes with a calibration microphone, connect it to your device. Otherwise, connect an omnidirectional microphone to your computer and make sure that you have the associated calibration file.
2. [Download](#) and install Dirac Live.
3. Make sure that your computer is connected to the same network as the target device.
4. Start Dirac Live.

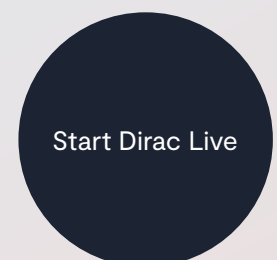
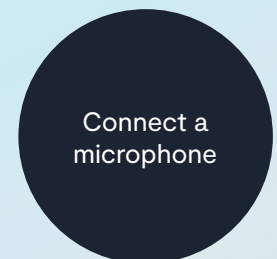

Room Correction Steps

This guide will go through each step to achieve the best possible sound.

User account and audio system

1. Log in (recommended) or continue in anonymous mode.

Depending on your audio device logging in may be optional. However, being logged in is required for access to any features beyond those provided through the audio device itself.

2. Select your audio device from the list.

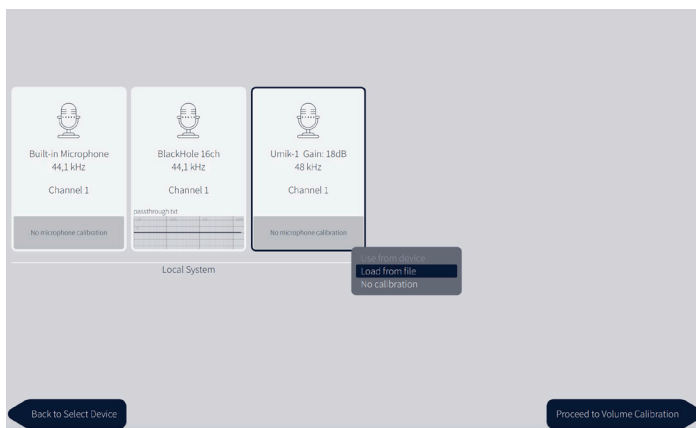

The Umik-1 has been selected as the measurement microphone and we are about to load a microphone calibration file.

3. Select the microphone to use (usually the one you connected during set-up). Use the context menu of the item to select *Use from device* to use the associated calibration or *Load from file* if you have an external calibration file. Selecting *No calibration* bypasses any compensations to the raw input stream and is generally not recommended.

Make sure that the microphone calibration file is created for 90-degree measurements.

4. Press “*Proceed to Volume Calibration*”.

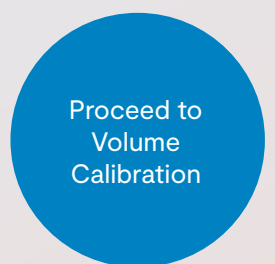
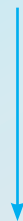
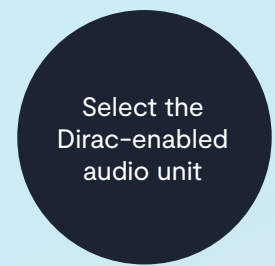

Volume calibration

Since the filter design algorithm requires that the speakers are measured with a decent sound pressure level and a quite low noise level, it is crucial to do a level calibration of the system before measurement.

Note that adjusting speaker gains in the volume calibration step is only for measurement and will not affect exported speaker gains.

1. To not damage your ears or speakers, the “Master output” level must be set to a low volume before you carry on with the volume calibration. If it’s not already set to a low volume, drag the magnitude indicator to the lower part of the slider.
2. Press the play button beneath the speaker located furthest to the left. The speaker should now play noise. If you can’t hear the noise, then slowly raise the “Master Output” level until you can hear it.
3. Repeat this procedure for all speakers. If there is no noise playing from one or more speakers, make sure that your device is configured to the correct speaker configuration and that your speakers are connected to the device.

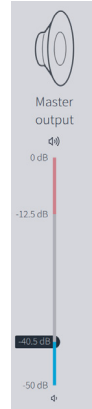

The Master Output level is set to a lower volume.



The sound pressure indicator reaches the green zone on all speakers.

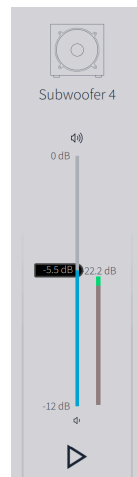

Attenuating the speaker that clips.

4. After you’ve confirmed that all speakers play noise, then play the noise from the furthest left speaker again. Raise the “Master Output” level until the sound pressure indicator reaches the green zone.

Note: the volume should *never* be painful to hear, you will still get a good result even if the green zone is not reached.

5. A common issue is that you get a clipping error during the measurement procedure. This can be fixed by dragging down the magnitude level a few dB for the speaker that caused the clipping.
6. Proceed to Select Arrangement.

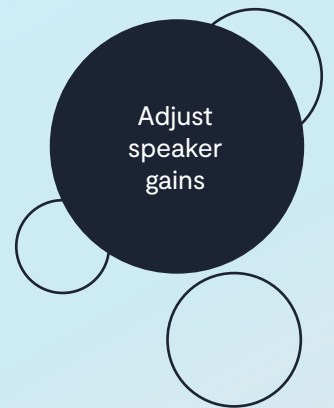

Proceed to
Select
Arrangement

Select Arrangement

Select the arrangement that best fits the listening space that is to be measured, then proceed to Measurement.

The different arrangements are there as guides to position the microphone and only differ in number of measurement points and their suggested locations.

Measurement procedure

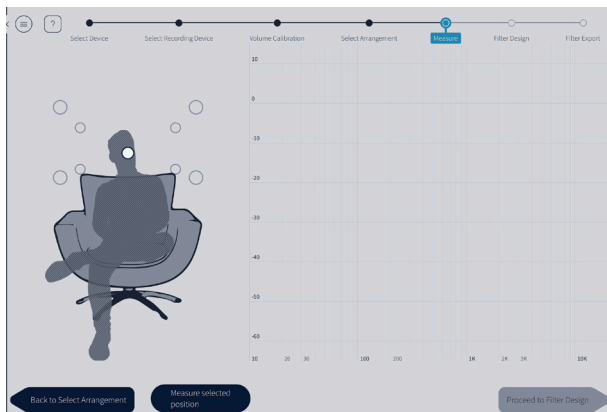

The selected measurement position is the main position. The delays and gains will be calculated based on this position.

1. The first measurement should always be taken in the center of the listening region, in the “main position”, as this will be used for alignment of levels and delays between loudspeakers.
2. Press the measure button to collect a set of measurements. This will play a sweep in each loudspeaker and one final sweep in the first loudspeaker again.
3. Move the microphone to the next suggested position and press measure. Repeat this procedure for all measurement points or until you have spanned the whole seating area.
4. Proceed to the filter design page after all recommended positions have been measured.



Tips for a good measurement

There is no strict way of positioning the measurement points; however, there are some things that are worth to have in mind during the measurement procedure:

1. The basic principle is that any additional measurement improves the correction. However, depending on the acoustics of your room and equipment the benefit from more measurements may diminish faster. Therefore, note that you do not necessarily need to do all the measurements defined in the arrangement. However, we strongly recommend you to never do fewer than five measurements.
2. The measurement points should have a distance of at least 30 cm (12 inches) between each other.
3. Avoid making measurements in a too-small space. Even for the “*Tightly focused*” listening environment, it is important to spread out the microphone positions to a sphere of at least 1 metre in diameter. A too small space will result in over-compensation and sound dry and dull.
4. Measure some points outside the listening area, e.g., for a sofa, it is recommended to do a few of the measurements 20-30 cm in any direction outside the couch.
5. Remember that you are measuring a volume rather than a surface and be certain that you take the measurements in different vertical positions as opposed to in a single horizontal plane.
6. Point the microphone upwards to the ceiling (90 degrees) when measuring to ensure that additional colouration from the microphone is similar for both the wall reflections and the direct wave from the speaker.
7. Remember that the positions specified in the arrangements act as a guide and you may deviate from them to put or decrease emphasis on particular spaces.

Filter Design

1. There are three alternatives for Bass Control: “Off”, “Upmix Only” and “Full Bass Optimisation”:

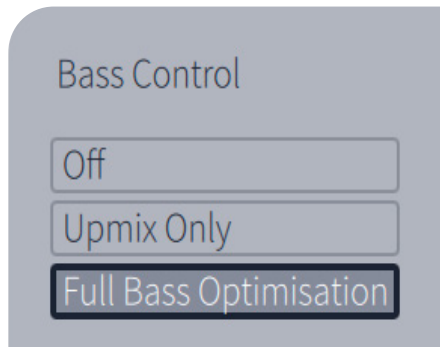

The three different Bass Control filter design alternatives “Off”, “Upmix Only” and “Full Bass Optimisation”.

- a. When **Off** is selected, the filter design page is presented without Dirac Live Bass Control instruments and standard Dirac Live filters are calculated.
- b. By selecting **Full Bass Optimisation** or **Upmix Only** the filter design page will be adjusted to accommodate Dirac Live Bass Control instruments.

By selecting “Upmix Only”, regular bass management filters with Dirac Live filters are designed and each subwoofer gain is scaled by $1/(\text{number of subwoofers})$ to match the target curve. Selecting the “Full Bass Optimisation” the filter design will harmonise the subwoofers and non-subwoofer speakers in the lower frequencies using tailor made phase filters, delays and gains.

2. After selecting “Full Bass Optimisation” or “Upmix Only”, several magnitude response plots will be shown in the graph. These plots present the average magnitude response of the selected speaker, as well as all subwoofers, and are there to guide the user to choose the best cross-over frequency for the system.

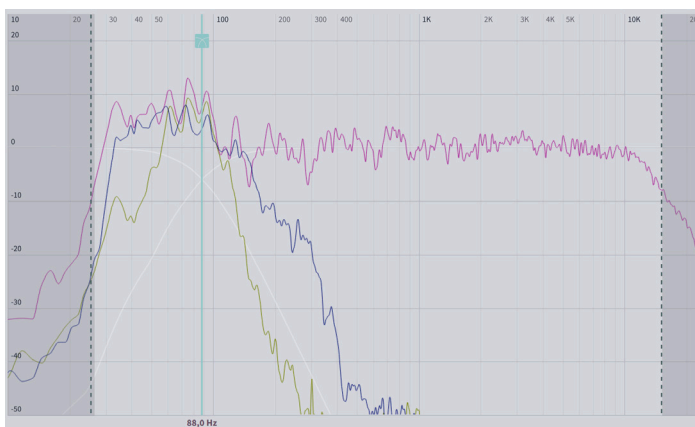

Average magnitude response of the selected speaker and subwoofer(s).

Enable
Bass Control

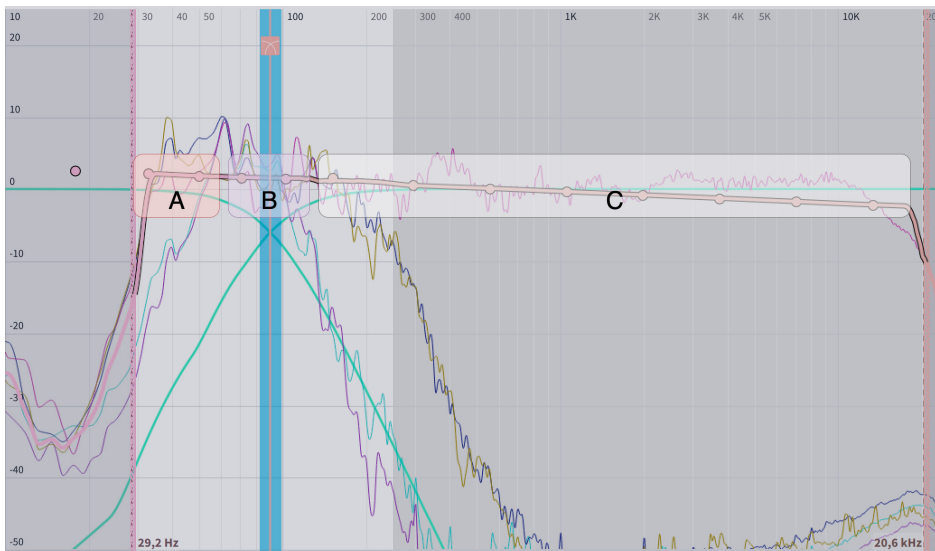

Input target curve in pink and cross-over area in blue.

3. Set the cross-over point. Select a cross-over frequency where both the high-range speaker and the subwoofer(s) have energy. The cross-over frequency can be adjusted by dragging the cross-over bar.

The cross-over filters are highlighted when hovering over the cross-over bar. Illustrated above, the lower section (A) of the cross-over filter describes which frequencies are passed down to the subwoofers. Section (B) describes which frequencies that are passed to both the subwoofers and the high-range speaker, and the upper part (C) describes which frequencies that are passed to the high-range speaker.

Note that each speaker group has their own individual crossover frequency.

In the next illustration there are four subwoofers of two different types, two broad-banded and two narrow-banded. To ensure that the narrow-banded subwoofers do not play outside its capable frequency region the cross-over is set to a few Hz below the narrow-banded cut-off frequency. Notice how the low-pass crossover filter follows the natural falloff of the narrow-banded subwoofers.

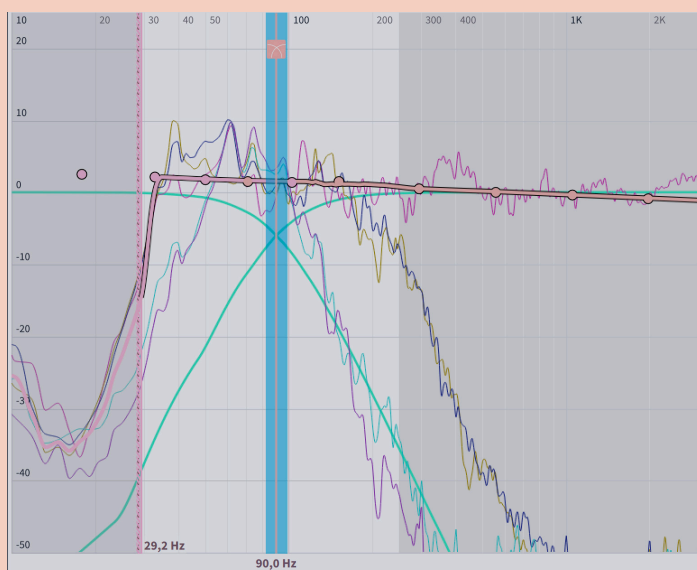

Low-pass Cross-over filter follows the natural falloff of the narrow banded subwoofers.

Adjust
cross-over
position

4. In Dirac Live Bass Control, just as in Dirac Live, the colour of the sound is set through a target curve. Though it is interacted with in the same way as when only using Dirac Live 2, the target curve when using Dirac Live Bass Control works differently.

In Dirac Live 2 the target curve setting the sound colouration was unique to the speaker group. For Dirac Live Bass Control, however, the lower frequencies are highly correlated between speakers, and a better compensation is achieved by separating the target curve into a low-frequency part common to the system and a higher-frequencies part unique to the speaker group. This new concept of target curve is described below:

- a. For any selected group, the input target curve consists of the bass-controlled range, which is common to all channel groups, as well as the range of higher frequencies, which is unique to that group. While the bass part of the target curve will be shared, each group can specify their own cross-over point from where the bass control will relinquish control to the requested colouration for the group.

Referring to the figure in step 3, above, the lower section (A) describes the colouration of how the subwoofers sum up together, where section (B) shows how the subwoofers and high-range speaker interact over the cross-over region. Section (C) describes the desired colouration for higher frequencies for the chosen speaker.

- b. The target curve defaults to a flat correction, which is the audio uncoloured and as close to the source sound as possible, which may not be what you prefer. Drag the target-points on the target curve to change to colouration to your preferred taste. You can always add more points by right-clicking on the target curve and select "Add control point to".
- c. Dragging the curve upward above the 0 dB level on the Y-axis boosts the affected frequencies. Correspondingly, dragging the curve downward under the 0 dB level attenuates them.

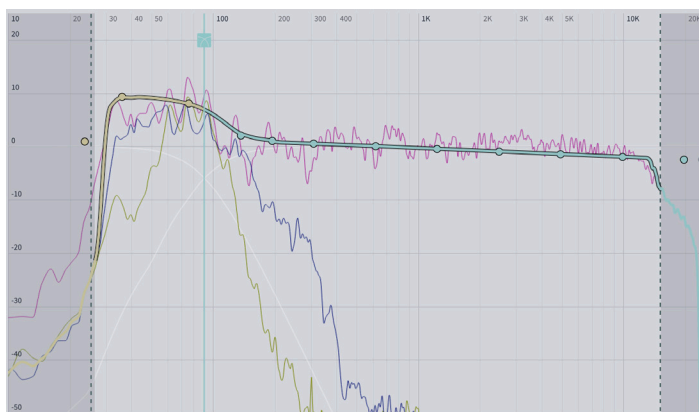

The Dirac Bass Control input target curve.

5. Increasing the volume of the subwoofers can be achieved by raising the part of the target curve under 100 Hz by a few dB, illustrated below. This is often wanted when watching movies.
6. Press "Calculate" in the lower right corner. The bass control filters will now be calculated.

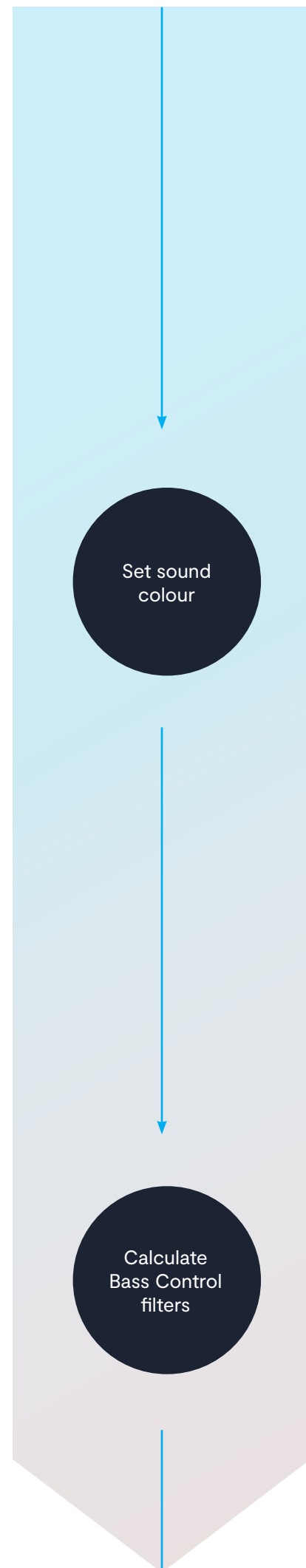

- After the Bass Control calculation is done, select the “Corrected” check-box in the plot options to show the resulting input magnitude response for the selected channel. The corrected curve should conform to the target curve, as illustrated below.

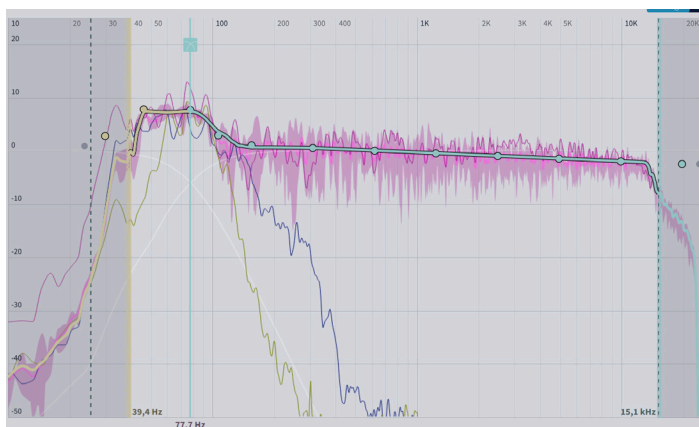

Bass Control result.

- Press “Proceed to filter export”.

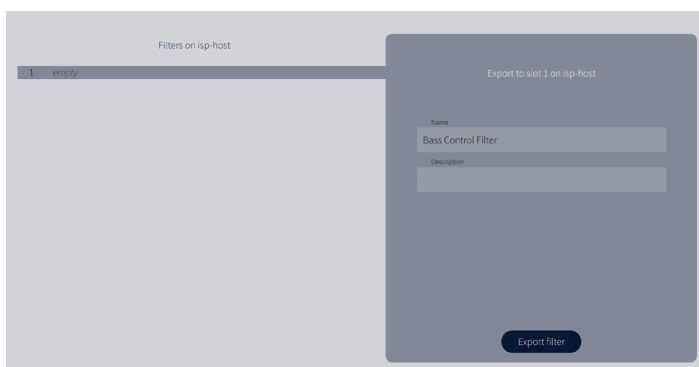

The filter export interface.

- Select a suitable slot and give the filter a name and, optionally, a description. If the slot is already occupied, the filter will be overwritten by the new filter.

When the export is completed the filter is deployed on your audio device and is ready to be used. Depending on your system the filter might be activated automatically or you may have to enable it manually.

Be certain to save your work if you want to make adjustments to it in the future.

Proceed to
Filter Export

Export filter
to your device

2. Technical Background

Lars-Johan Brännmark
Edited by Mikael Ueno Andersson

This section presents the background principles and intended workflow for how to use the Dirac Live Bass Control solution for multi-channel audio systems with subwoofers, developed at Dirac Research AB.

The Dirac Live Bass Control is intended to be used together with Dirac Live room correction, and it utilizes the same impulse response measurements as are used for Dirac Live. A characteristic feature of this solution is that it minimizes seat-to-seat variations at low frequencies in systems with multiple subwoofers. Another feature is that it ensures the high-range main channels to be in-phase with the subwoofers in the crossover frequency band, at a selected position in the room (in the application called the “*main position*“ and otherwise sometimes called the “sweet-spot”).

The design objectives are addressed primarily by adjusting phase relationships between the loudspeakers, using low-order all-pass filters and a genetic optimization algorithm.

Dirac Bass Control

The Bass Management Problem

Besides solving the standard bass management task (i.e., using crossover filters to extract the bass content from the input signals and routing it to the subwoofers), the proposed Bass Control solution also provides an automatic fine-tuning of delays, gains and phase shifts in the bass region of each loudspeaker, resulting in an improved overall bass performance. The fine-tuning of the loudspeaker channels is performed in multiple steps and strives to solve three different but related problems:

1. Reducing the spatial variability of the frequency responses in the bass region, in cases where the system contains multiple subwoofers.
2. Reducing out-of-phase behavior between the channels of left/right loudspeaker pairs, in a frequency band around the crossover frequency.
3. Reducing out-of-phase behavior between the subwoofers and the high-range channels, in a frequency band around the crossover frequency.

What is not tuned automatically in this solution is the crossover frequency itself, which is assumed to be either fixed or selected among a set of fixed values by the user.

Why Dirac Live Bass Control?

Broadly speaking, bass management is the process of configuring an audio system so that the bass content of the incoming signals is directed to the loudspeakers that are best suited for reproduction of low frequencies. The aim of Bass Control is to ensure that all low frequency content, regardless of input channel, will be perceived by the listener even if some of the loudspeakers are lacking in low frequency capability. The frequencies referred to here are typically in a range from 20 Hz up to about 80Hz. The reason why Bass Control generally works well is that sound in this frequency range provides very little or no directional information to human listeners, especially in spaces where the room modes dominate over the direct sound. Thus the bass signal intended for one loudspeaker can be redirected to other speakers without significantly affecting the perceived direction of the reproduced sound.

Limitations

In general, the bass-capable loudspeakers could be one or several of the main system loudspeakers, e.g., the main front stereo L/R pair if these are large enough, or they could be one or several subwoofers, or any combination of subwoofers and large main speakers. In order to keep complexity at manageable levels, however, some restrictions are necessary. In this version of Bass Control we shall therefore adhere to the following principles:

1. If a main loudspeaker is considered capable of reproducing frequencies down to 20 Hz, it should be labeled “Large” and be excluded from all Bass Control processing. The loudspeaker will be fed with nothing but the full-band content of its own input signal, and its input signal will not be fed to any other channel either. This can be done in the Dirac Live application by selecting a crossover frequency of 20 Hz for that specific speaker or group of speakers.

2. If a main speaker is not capable of reproducing low frequencies, then it should be labeled “Small” and be included in the Bass Control system. Its input signal will be split and processed by a pair of high-pass and low-pass crossover filters. The resulting high and low frequency branches are then routed to the speaker in question and to the subwoofers, respectively.
3. The LFE (Low Frequency Effects) channel, if such exists among the inputs, should be routed directly to the subwoofers without any crossover processing.

Details of Dirac Live Bass Control

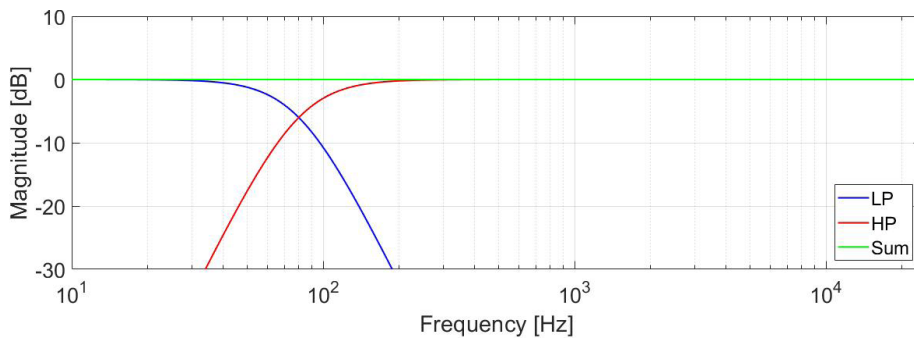

Figure 1: A pair of complementary 4th-order Linkwitz-Riley crossover filters, with a cutoff frequency of 80 Hz. The blue curve is the frequency response of the lowpass filter, and the red curve is the frequency response of the highpass filter. The green curve is the frequency response of the sum of the low- and highpass responses.

Crossover filters

The fundamental processing block in a bass management system is the crossover. Bass management cross-overs mostly consist of complementary low-pass and high-pass filters of second or fourth order, corresponding to filter slopes of 12 or 24 dB/octave, see e.g., Fig. 1, above. The block diagram of Fig. 2, below, illustrates how crossovers are typically used for bass management in the simplest possible case: A stereo setup with a pair of small L/R speakers and a subwoofer that reproduces the low-frequency part of a mono sum of the left and right inputs.

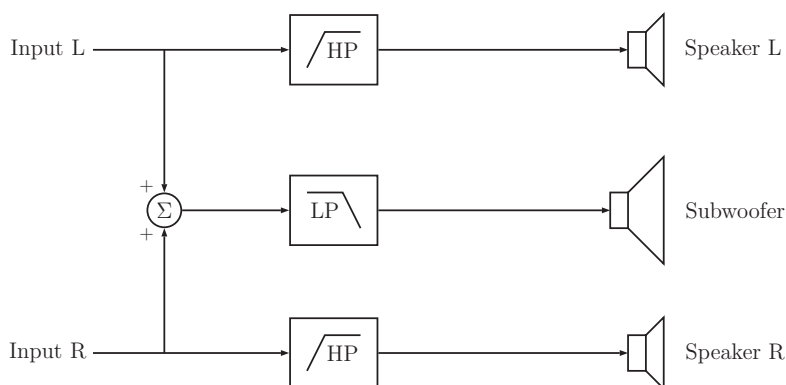

Figure 2: Block diagram of a simple bass management solution for a stereo system: The left and right input signals are highpass filtered and fed to the left and right main loudspeakers, respectively, and a mono sum of the left and right inputs is lowpass filtered and fed to a single subwoofer.

The crossover used in the the present Bass Control system are digital fourth-order Linkwitz-Riley filters with selectable cutoff frequency, as shown in Fig. 1. The choice of Linkwitz-Riley type filters is however not compulsory for the system to work as intended; what matters is that the filters are complementary in magnitude, which can also be attained with e.g., linear phase FIR crossovers.

Handling of multiple subwoofers

A desirable property of an audio system is to have a smooth frequency response that does not change significantly with listener position. However, at low frequencies the standing waves of a room can be quite dominant, causing the transfer functions of loudspeakers to be highly irregular; the frequency response contains sharp peaks and nulls, and the levels of the peaks and nulls vary dramatically with listener position. Fig. 3 shows the frequency responses of a subwoofer measured at 21 positions in a room. It is clear from the figure that although the average frequency response (thin black line) is smooth and well behaved, the response at each measurement position is very irregular, and the variations in level across positions are on the order of 20–30 dB at some frequencies.

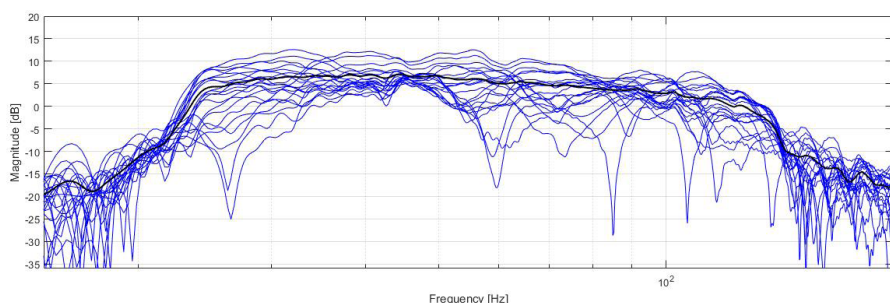

Figure 3: Frequency responses of a subwoofer, measured at 21 positions in a room (blue lines), and their RMS average (black line).

It is well known that the use of multiple subwoofers can help to mitigate such irregularities, especially if their locations, relative levels and phase relationships are chosen carefully so that they interact with the room and with each other in an optimal way. Using multiple subwoofers also helps to increase the dynamic headroom in the bass since the required electrical and mechanical power is then distributed over multiple speaker elements.

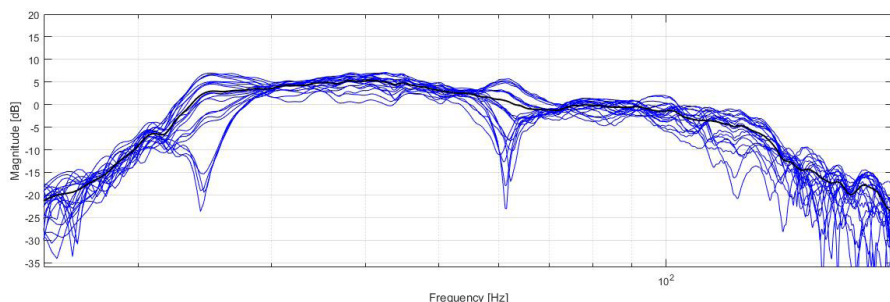

Figure 4: Frequency responses of the acoustic sum of three subwoofers, measured at 21 positions in a room (blue lines), and their RMS average (black line).

Fig. 4 shows the result of adding two subwoofers to the situation of Fig. 3, so that three subwoofers are connected to the same input signal. Clearly, the spatial variations are substantially reduced for most frequencies, but some variability still remains around 25 Hz and 60 Hz. Merely adding more subwoofers to the system thus seems quite helpful in reducing variations, but as the remaining variations indicate, the end result may not be fully predictable.

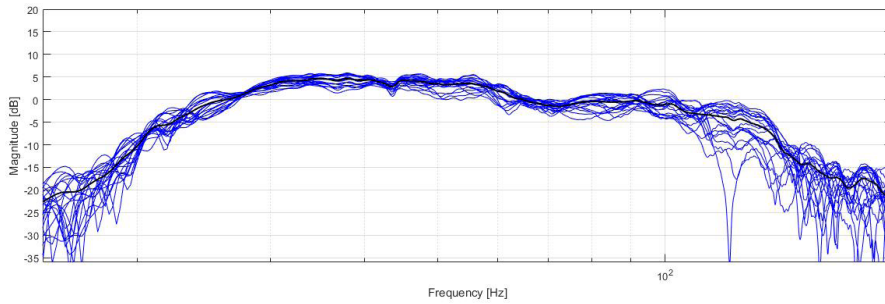

Figure 5: Frequency responses of the acoustic sum of the same three subwoofers as in Fig. 4, after applying a small level adjustment and two allpass biquad filters to each subwoofer. The allpass filters and level adjustments were tuned according to a criterion that minimizes the spatial variation of the frequency response between 30 and 100 Hz.

In order to get the most out of the multiple subwoofer scenario, the present Bass Control solution provides a fine-tuning of the levels, delays and phase responses of individual subwoofers, under a criterion that the variations across space are minimized in a selected band of frequencies. Fig. 5 shows the result of such a fine-tuning, where a gain factor and two all-pass bi-quad filters have been applied to each subwoofer.

Single channels and stereo pairs

Our Bass Control filter design is somewhat more straightforward for single channels than for stereo left/right channel pairs. For the first channel (e.g., the center channel C in a 5.1 setup), the Bass Control filters consist of:

1. A pair of complementary high-pass and low-pass crossover filters. The low-pass filter extracts the low frequency part of the input signal and sends it to the subwoofers, and the high-pass filter removes the bass and sends the remaining high-frequency part of the signal to the center loudspeaker.
2. A pre-specified number of all-pass biquad filters applied to each of the high- and low-frequency signal branches. The role of these all-pass filters is to ensure that the subwoofer and center channel transfer functions are in-phase around the crossover frequency, at a selected *main position* in the room, so that no destructive interference occurs in the crossover band.

With the summation of the left, right, and two subwoofer speakers after the crossover has been applied our example data shows a null around 40 Hz as a result of destructive interference between the speakers. In comparison, the same summation with finetuned all-pass filters applied to the respective speaker will result in improved phase-match between speakers and a suppressed null.

Generalized Low-frequency Support

Since full-range speakers can produce frequencies below 100 Hz, we can contribute to the optimization by including them into the bass control design. As seen in section *Handling of multiple subwoofers*, by adjusting levels, delays, and phase responses of the individual subwoofers, it is possible to minimize the variation between the measurement points and get a more unified listening area. Correspondingly, it is a planned Bass Control feature that the user will have the ability to include their full-range speakers into the Bass Control optimization. From the optimization design perspective, a full-range speaker will be seen as both a small-range speaker and a subwoofer.